



*Quality Through Innovation Since 1987*

# Interfacing Sensors & Transducers to Data Acquisition Systems in which Large Common Mode Signals are Present

By Brad Albing

### Abstract:

A discussion of methods of amplifying and signal-conditioning for sensors with low level outputs in the presence of high ambient electrical noise sources. Advantages and disadvantages of some common amplifier circuits are considered.

Sensors or transducers used in data acquisition systems may have low-level outputs on the order of a few millivolts or milliamperes; or may take the form of a variable resistance on the order of kilo-ohms. Transducer examples include piezo, quartz, condenser, electret, photosensitive (optical) and MEMs devices – commonly used to detect vibration, acceleration, seismic activity, pressure, angle of inclination, light levels, and sound.

Signals from these transducers need amplification. But besides the signals that the transducer produces, there is usually undesirable electrical fields nearby that cause problems. Any additional electrical variations present but undesirable are collectively referred to as noise. Noise sources most commonly encountered are powerline “hum” and switching transients; and clock signals from nearby computers or microprocessors.

Transducers are often two-terminal devices. If the transducer is ground referenced (i.e., one terminal connected to circuit common or ground), it can be thought of as a single-ended devices whose signal can be sent to an amplifier with a single-ended input. In consideration of noise as described (above), note that there is actually signal + noise voltage sent to the amplifier. An example: A thermistor has one end connected to ground and the other end connected to a resistor that in turn connects to a low DC voltage (e.g., +5 V). The junction of the resistor and the thermistor is connected to an op-amp configured as an amplifier. Temperature variations produce a varying voltage at the output of the amplifier. But the relatively high resistance of the thermistor circuitry leaves it susceptible to noise.

Noisy signals need filtering that often takes the form of a low-pass filter (LPF). The LPF can remove some extraneous noise, such as powerline interference and clock signals. Note that these are electrically coupled noise sources, not magnetically coupled. Mitigation of magnetically coupled noise sources is beyond the scope of this Application Note.

Some two-terminal transducers are non-ground referenced and could therefore not be connected to a single-ended input amplifier. Instead, they would have both of their terminals connected to a differential input amplifier/LPF. A microphone with a balanced output connection or a strain gauge that is part of a full (four-element) bridge represents a typical example. With differential sensors, noise is still a problem. However, the noise is often coupled into the two sensor leads in amounts almost equal in magnitude and phase. Thus, the noise is present as a common mode voltage while the sensor signal of interest is present as a differential mode voltage. An ideal differential amplifier has infinite input impedance at each input, equal frequency response at each input, and equal gain but with inverted gain polarity between each input.

A simple differential amplifier using one op-amp is shown in Figure 1. At first glance, this seems like a good choice to amplify the output of a non-ground referenced transducer.

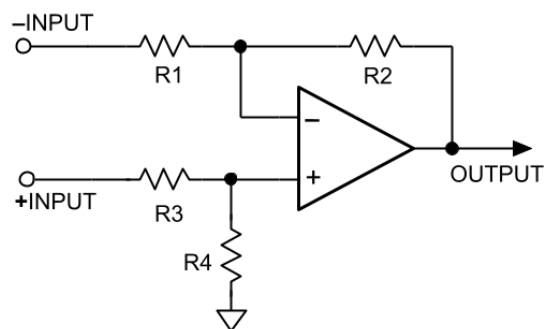

**Figure 1: Differential Input Operational Amplifier**

If  $R1$  through  $R4$  are the same value, the voltage gain for a signal from a true voltage source (zero internal impedance) applied at the  $-INPUT$  is  $-1$  V/V. Similarly, the voltage gain for a signal applied to the  $+INPUT$  is  $+1$  V/V. If the  $+INPUT$  is connected to ground and a battery whose output was exactly  $1.0$  V were connected from ground to the  $-INPUT$  (with its positive terminal to that input), the amplifier's output would be  $-1.0$  V. Connected instead to the  $+INPUT$  with the  $-INPUT$  grounded, the output would be  $+1.0$  V. A voltage source of any value (within the operating range of the amplifier) connected to both inputs (tied together) will produce nothing at the output. This is the heart of how a differential amplifier rejects common mode voltages.

While this amplifier appears to meet the requirements for the non-ground referenced transducer cited above, it has a significant problem. The input resistance looking into each of the two inputs is different. For the  $+INPUT$ , it's  $R3 + R4$ ; for the  $-INPUT$ , it's just  $R1$ . That's because with an op-amp, the summing junction (the node where  $R1$  and  $R2$  connect to the op-amp's negative input) is a virtual ground. Worse yet, when high frequencies are present, instead of input resistance, input impedance must be considered. This includes the resistors, any parasitic shunt capacitance associated with the resistors, input capacitance at the op-amp's two inputs, and stray capacitance to ground. Parasitic inductance is present, but usually not a concern for most sensor applications.

These mismatched input impedances degrade the ability of the amplifier to reject common mode voltages present on non-ground referenced transducers. Note that the common mode voltages can easily be an order of magnitude or greater with respect to the differential mode voltages of interest. The figure of merit that describes ability to ignore or reject the common mode voltage is the common mode rejection ratio (CMRR).

Note that besides noise, transducers that are part of a four-element bridge circuit (e.g., a strain gauge) will likely have a DC voltage present (the excitation voltage) that elevates the transducer significantly above ground. Again, the differential amplifier must reject this common mode excitation voltage and just amplify the differential mode voltage from the strain gauge.

The most common work-around to deal with this lack of matching is to buffer each of the two inputs with op-amps. These two op-amps can be configured for unity gain or more, as long as the gains and offset voltages are closely matched. Such a configuration is an instrumentation amplifier (IA) and is shown in Figure 2.

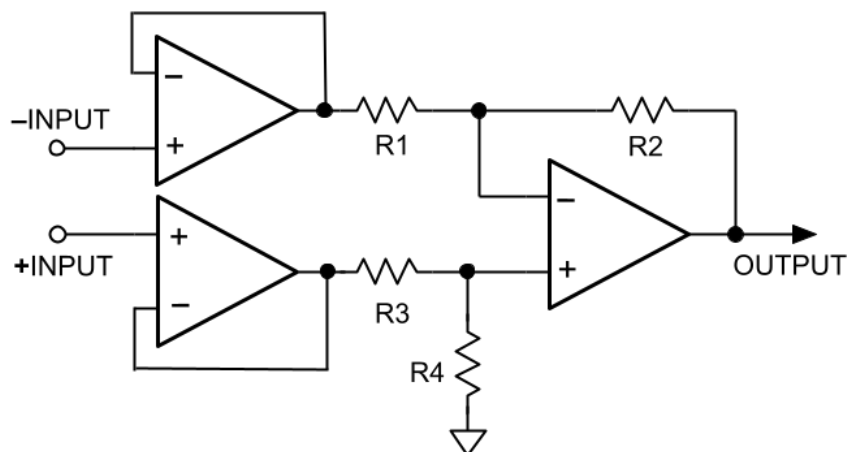

**Figure 2: Simple Instrumentation Amplifier**

The IA appears to solve the problems cited above. It does not completely. Although not shown in Figure 2,  $-INPUT$  and  $+INPUT$  must have resistors connected to ground to supply a path for the op-amps input bias current. The resistors' values can be large (perhaps in the many  $k\Omega$  range) and must be closely matched. To the extent there is a mismatch in resistance, CMRR is degraded. As before, further degradation occurs due to the parasitic capacitance present both between the inputs and ground. Any capacitance mismatch results in a degradation of CMRR.

To alleviate these shortcomings, a better method relies on a matched pair of junction field effect transistors (JFETs). The [LSK489](#) is an excellent choice: dual JFETs, weaved together in a proprietary way on a single, small die. This results in the  $C_{iss}$  (input capacitance) and related parasitic capacitances being low and being well matched. Typical  $C_{iss}$  is 4 pF. This helps improve CMRR. And the single die means dual FETs track better over the full temperature range.

Additional advantages provided by the [LSK489](#) dual JFET: That  $C_{iss}$  spec is lower than some commonly used JFETs, MOSFETs, or bipolar transistors; the reduced  $C_{iss}$  reduces intermodulation distortion.

Besides these general benefits pertaining to IAs, the [LSK489](#) is an excellent choice for audio circuits which may be powered from relatively low voltage (battery operated portable equipment) up to higher voltages such 48 V (phantom-powered microphone circuits). The matched low gate threshold voltage, matched high transconductance, low noise, and matched low capacitance make it the perfect choice for many audio applications.

Moving on to some real-world circuits, consider Figure 3. An [LSK489](#) is configured as a differential input pair. Instead of simply using drain resistors, PNP transistors are used. Configured as an additional differential pair, they increase the transconductance of the differential input stage, increase CMRR, and provide some negative feedback. This negative feedback reduces the stage's distortion.

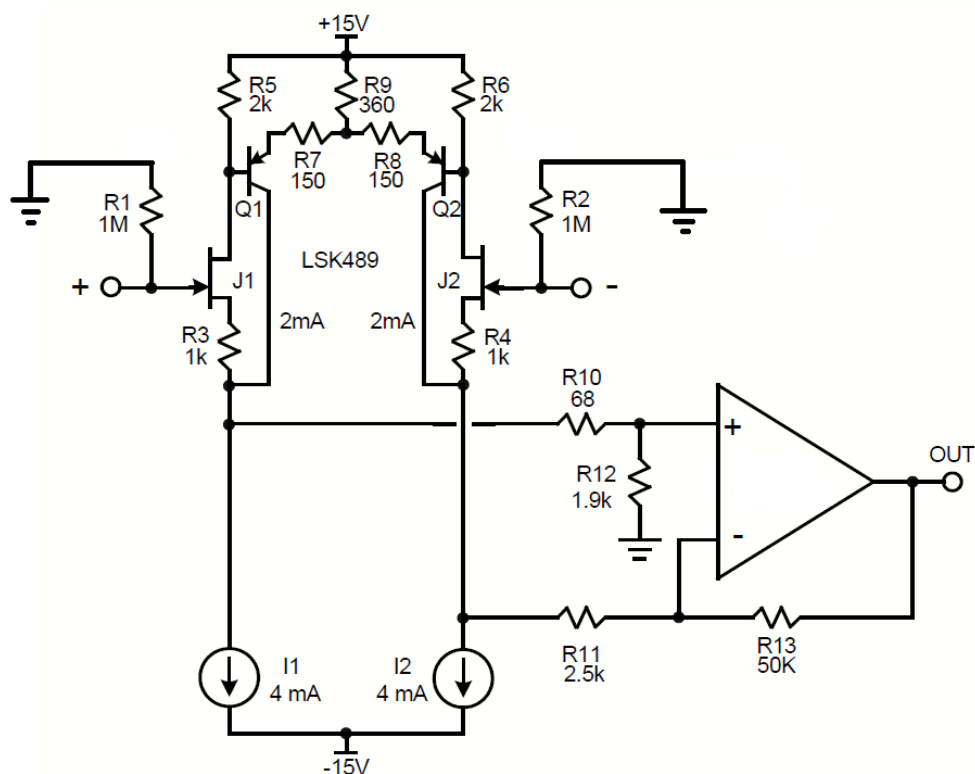

**Figure 3: Differential Input Composite Amplifier**

This combination of discrete FETs for the input stage plus a bipolar junction transistor (BJT) op-amp is referred to as a hybrid or composite amplifier. This configuration provides performance difficult to obtain in an all BJT or all FET IC op-amp. The FETs have virtually no input bias current and noise current, although they typically have higher noise voltage than BJTs. It is difficult to fabricate good JFETs in the fab process used for BJTs, so the sensible approach uses discrete FETs in front of a good quality, low noise op-amp. For a more detailed look at composite amplifiers along with more details on JFET operation, refer to the [LSK489 Application Note](#). Additional information on FET operation and noise sources can be found in the [LSK389 Application Note](#).

In application in which a higher bandwidth is needed, a cascode circuit can be used. The cascode configuration greatly reduces Miller effect multiplication of capacitance (gate-to-drain) which helps increase bandwidth. The cascode configuration is implemented by using a second pair of FETs as part of the input FETs drain load resistors. The upper two FETs act as source followers and allow the output of the op-amp to drive the drain voltage of the two input FETs. This effectively lowers the input capacitance for these lower two FETs. Additionally, the upper two FETs' drain voltages vary with the differential input voltage which controls the op-amp's inputs.

The cascode configuration also reduces the source-to-drain voltage of the input FETs. This generally reduces noise and power dissipation in the input FETs and is also useful if the supply rail voltage exceeds the breakdown voltage of the FETs. Figure 4 shows a typical application.

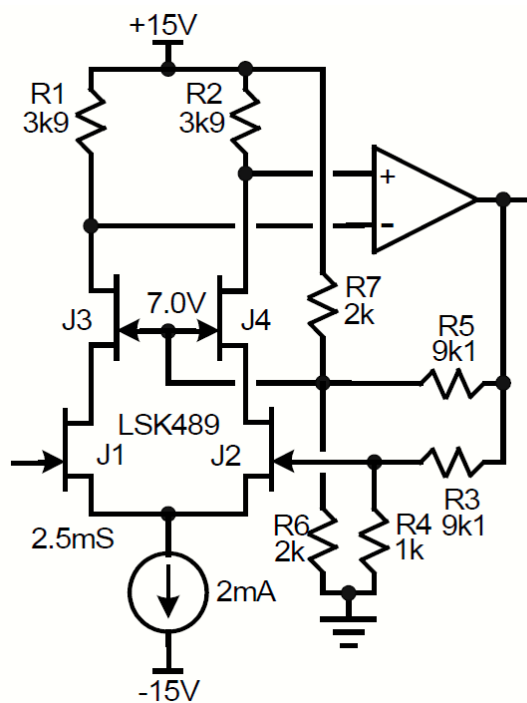

Figure 4: Driven Cascoded FET Pair

**Conclusion:**

Degradation of sensor signals can occur due to common mode noise sources and poor CMRR of the signal conditioning circuitry. Careful design techniques and well-thought-out amplifier circuitry is mandatory in order to extract signals in electrically noisy environments.