



Quality Through Innovation Since 1987

Common Mode Rejection Ratio in Dual Junction Field Effect Transistors

By Kirkwood Rough and Timothy S. McCune

Differential amplifiers made with discrete transistors have significant noise and performance advantages. A single JFET amplifier will provide excellent impedance matching and low-noise amplification. Using a dual JFET wired as a differential amplifier will also largely reject common signals. This important characteristic – Common Mode Rejection – means that selecting the right dual JFET will be the most cost-effective way of improving signal-to-noise ratio in your design. You can't overlook how the part's internal design affects the rejection of unwanted inputs while amplifying the signal as accurately as possible.

All dual JFETs achieve Common Mode Rejection to some extent, but creating a part to optimize this requires specialized design techniques. Linear Systems Founder John H. Hall led this work in the early 1960s as a protégé to industry pioneer Jean Hoerni at Union Carbide's semiconductor division. The need for electrical characteristic matching by the two halves of the dual component over a wide range of temperatures was obvious, but deviations in epitaxial surfaces and other issues made this design work challenging. After heated arguments with more senior developers at Union Carbide, Hall eventually convinced Hoerni to let him try his approach.

Dual transistors – bipolars as well as JFETs – had to that point been created from two separate pieces of silicon. Each die would be tested for specific electrical characteristics and then matched by hand in a special package. At room temperature, duals made this way would match, but as temperatures changed, the characteristics of the separate halves deviated from each other.

To correct this problem, Hall envisioned the most intricate dual design yet conceived. Rather than each half of the dual being set side-by-side, he would weave the transistors together. This design enabled unprecedented matching over a wide range of temperatures, creating very high Common Mode Rejection Ratios.

First with bipolar transistors and later with JFETs, Hall improved the designs of these so-called monolithic tightly matched duals over the course of a 50-year career. Hall and his design team developed new and more capable cross-coupling methods to provide current distribution nearly identical in each half of the dual component. This achieved ultra-close matching over a wide range of temperatures, the key to having consistently high Common Mode Rejection.

Common Mode Rejection Ratio, expressed in dBV, is the common coupled voltage influence over frequency on a differential amplifier input stage. The input of a discrete differential amplifier, most often, is a dual gain element such as a dual Bipolar junction transistor, MOS or junction type Field Effect transistor, Thermionic Triode, Etc. Ideally the input gain element pair is perfectly matched in transconductance (G_m), offset (ΔV_{in}), temperature coefficient (Δt), and noise (V_n). However any two gain elements separated by a finite space will inevitably have differences in these characteristics as a function of spatial differences in fabrication. John Hall's cross-coupled dual device structure was what evolved to mitigate this problem.

¹ The measure of a differential amp's performance in rejecting undesirable common-mode signals is the ratio of the differential voltage gain ($A_v(d)$) to the common-mode gain (A_{cm}). This ratio is the CMRR.

The measure of a differential amp's performance in rejecting undesirable common-mode signals is the ratio of the differential voltage gain ($A_v(d)$) to the common-mode gain (A_{cm}). This ratio is the CMRR.

Limiting this to Junction FET's, two equally fabricated parts on a silicon wafer adjacent to each other will have differences in doping distribution concentrations, crystal uniformity and thermal offset during processing. Whereas, if both parts occupied the same space, or nearly so, distribution of fabrication differences would approach the same values and therefore approach the ideal. To that end, these JFET device structures are merged, so that the dies are a uniformly interleaved area of both JFET's.

For instance, the [LS840](#) series of Dual JFETs fabricated this way exhibit low common mode noise, and tight matching of VGS and Gm. When used as a differential amplifier, common mode input voltage influence to the differential input voltage is minimized to its lowest value when the sources are current source biased, (High CMRR).

Common source constant current biasing maintains an invariant total drain current regardless of input signal differential amplitude having a common mode voltage influence. (**fig a**) A resistive current bias will have a varied source current and present a ΔV gain where common mode V is involved. (**fig b**) An Audio amplifier potentially benefits from resistive bias by the slight gain variation influence of input signal amplitude promoting even order harmonics. However, Instrumentation amplifiers need high linearity and typically use a constant current source bias. This results in constant total drain current with no gain modulation. Common mode voltage influence on the signal path is significantly diminished when a current source resistance approaches infinity.

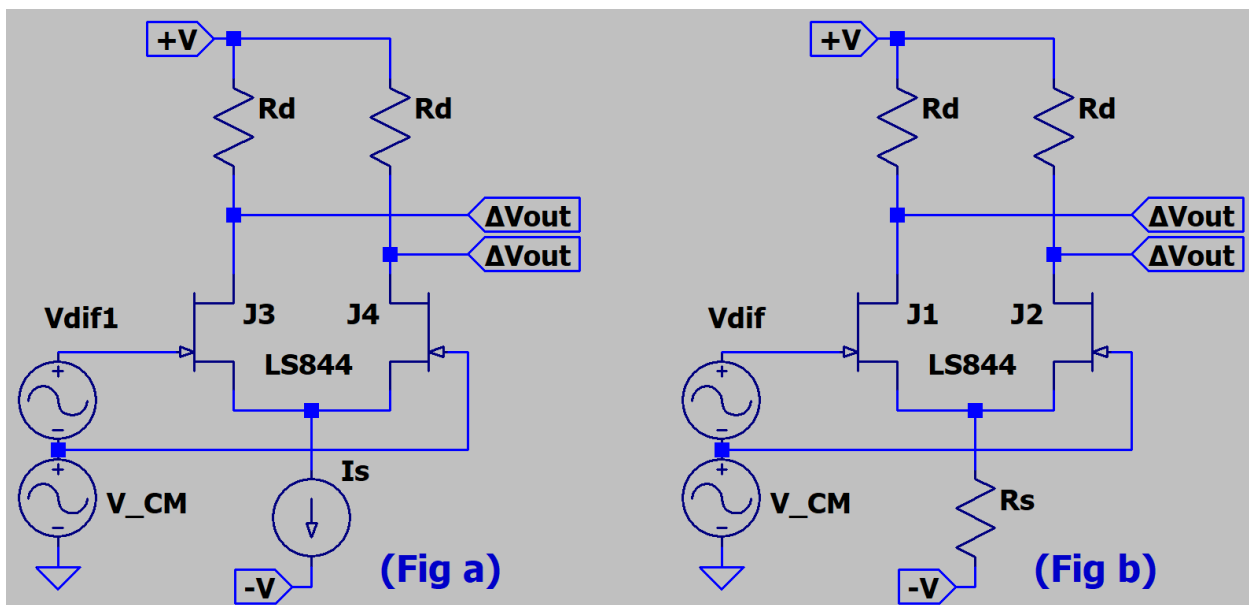

Linear Systems' Line of High-CMRR Monolithic Dual Components

Leading Products:

The LSK389A, B, C and D grades of high performance monolithic dual JFETs feature extremely low noise, tight offset voltage and low drift over temperature specifications

[LSK389 Series Datasheet and Spice Model](#)

[LSK389 Series Application Note](#)

The LSK489 A and B grades are the industry's optimal combination of low input capacitance and extremely low-noise in a monolithic dual N-Channel JFET

[LSK489 Datasheet and Spice Model](#)

[LSK489 Application Note](#)

The [LS844](#) Ultra-Low Noise, Low-Drift, Monolithic Dual N-Channel JFET Amplifier combines low noise, low input capacitance and our lowest price for a monolithic dual

[LS844 Series Datasheet and Spice Model](#)

[LS844 Series Application Note](#)

The [LS310](#) Series Tightly Matched, Monolithic Dual, NPN Transistor is a direct replacement for Analog Devices MAT series and National LM3494 series

[LS310 Series Datasheet and Spice Model](#)

The [LS350](#) Series Tight Matching, Monolithic Dual, PNP Transistor is a direct replacement for Analog Devices MAT series parts. It is ideal for Tight Matching, Small Signal, Transistors Amplifier & Switching Applications

[LS350 Series Datasheet and Spice Model](#)

[Designing with the LS310 & LS350 Bipolar Transistor Series](#)

General Monolithic Dual JFET Products

LS5905, 5906, 5907, 5908 & 5909 Series, Low-Leakage, Low-Drift, Monolithic Dual, N-Channel JFETs

[LS5905 Series Datasheet and Spice Model](#)

2N5564 Low Noise, Monolithic Dual, N-Channel Higher-Frequency JFET

[2N5564 Datasheet and Spice Model](#)

LS5911, 5912 & 5912C is a Wideband, High Gain, Monolithic Dual, N- Channel JFETs

[LS5911 Series Datasheet and Spice Model](#)

LS830, 831, 832 and 833 Ultra-Low Leakage, Low Drift, Monolithic Dual N-Channel JFETs

[LS830 Series Datasheet and Spice Model](#)

LS840, LS841 and LS842 Low Leakage, Low Drift, Monolithic Dual N-Channel JFETs

[LS840 Series Datasheet and Spice Model](#)

The SST/U401, 402, 403, 404, 405 and 406 Low-Noise, Low-Drift, Monolithic Dual N-Channel JFETs

[SST/U401 Series Datasheet and Spice Model](#)

LS3954, 3954A, 3955, 3956 and 3958 Low Noise, Low Drift, Monolithic Dual, N-Channel JFETs

[LS3954 Series Datasheet and Spice Model](#)

U421, 422, 423, 424, 425 and 426 Low-Noise, Low-Drift, Monolithic Dual N-Channel JFETs

[U421 Series Datasheet and Spice Model](#)

SST/U440 and U441 Wideband, High-Gain, Monolithic Dual N-Channel JFETs

[SST/U440 Series Datasheet and Spice Model](#)

LSJ689 high performance, P-Channel, monolithic dual JFET features extremely low noise, tight offset voltage and low drift over temperature

[LSJ689 Datasheet and Spice Model](#)

[LSJ689 Application Note](#)

General Bipolar Transistor Dual Products:

The IT120A Series Monolithic Dual, NPN Transistor is a direct replacement for the Intersil IT120 Series

[IT120A Series Datasheet and Spice Model](#)

The IT124 Monolithic Dual, NPN Transistor, Super Beta is a direct replacement for Intersil IT124

[IT124 Series Datasheet and Spice Model](#)

The IT130A Series Monolithic Dual, PNP Transistor is a direct replacement for Intersil IT130 Series

[IT130A Series Datasheet and Spice Model](#)

The LS318 Log Conformance, Monolithic Dual, NPN Transistor is a direct replacement for Micro Power Systems MP318 Series

[LS318 Datasheet and Spice Model](#)

The LS3250 Series Tightly Matched, Monolithic Dual, NPN Transistor is a Higher Current Version of the MP310, MP311, MP312, and MP313 Series

[LS3250 Series Datasheet and Spice Model](#)

The LS3550 Series Monolithic Dual and Single, PNP Transistor is a Higher Current Version of the MP350, MP 351, and MP352 Series

[LS3550 Series Datasheet and Spice Model](#)

The LS358 Log Conformance, Monolithic Dual, PNP Transistor is a direct replacement for Micro Power Systems MP358 Series

[LS358 Datasheet and Spice Model](#)

The LS301 Series High Voltage, Super Beta, Monolithic Dual, NPN Transistor is a direct replacement for Micro Power Systems MP301, MP302, MP303 Series

[LS301 Series Datasheet and Spice Model](#)